

greenworks

EN	3 GAL WET/DRY VACUUM CLEANER	OPERATOR MANUAL
FR	ASPIRATEUR EAU ET POUSSIÈRE 11L (3 GALLONS)	MANUEL OPÉRATEUR
ES	ASPIRADOR EN HÚMEDO/SECO DE 3 GALONES	MANUAL DEL OPERARIO



VUG402

www.greenworkstools.com

1	Description.....	4	8.3	Remove the filter.....	7
1.1	Purpose.....	4	8.4	Insert the hose.....	7
1.2	Overview.....	4	8.5	Install the battery pack.....	8
2	General power tool safety warnings.....	4	8.6	Remove the battery pack.....	8
2.1	Important safety instructions.....	4	9	Operation.....	8
2.2	Battery-operated appliances.....	5	9.1	Start the machine.....	8
3	Child safety.....	5	9.2	Stop the machine.....	8
4	Symbols on the product.....	5	9.3	Blowing feature.....	9
5	Risk levels.....	6	9.4	Operation tips.....	9
6	Environmentally safe battery disposal.....	6	10	Maintenance.....	9
7	Save these instructions.....	6	10.1	Clean the filter.....	9
8	Installation.....	6	10.2	Clean the machine.....	9
8.1	Unpack the machine.....	6	11	Store the machine.....	10
8.2	Install the filter.....	7	12	Troubleshooting.....	10
			13	Technical data.....	10
			14	Limited warranty.....	10
			15	Exploded view.....	11

1 DESCRIPTION

1.1 PURPOSE

This machine is intended for vacuuming dust in domestic use.

1.2 OVERVIEW

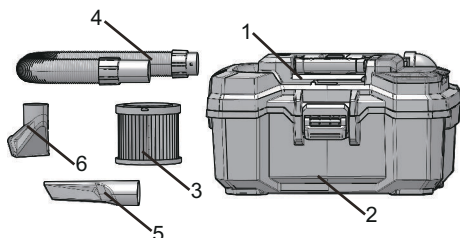

- 1 Top Cover Assembly
- 2 Collection Tank
- 3 Filter
- 4 Hose
- 5 Crevice Tool
- 6 Utility Nozzle

2 GENERAL POWER TOOL SAFETY WARNINGS

▲ WARNING

Read all safety warnings and all instructions. Failure to follow the warnings and instructions may result in electric shock, fire and/or serious injury.

Save all warnings and instructions for future reference.

The term “power tool” in the warnings refers to your battery-operated (cordless) power tool.

2.1 IMPORTANT SAFETY INSTRUCTIONS

For household use.

READ ALL INSTRUCTIONS BEFORE USING

▲ WARNING

Read and understand all instructions before using this product. Failure to follow all instructions listed below may result in electric shock, fire, and/or serious personal injury. When using an electrical appliance, basic precautions should always be followed, including the following:

The term “appliance” in all of the warnings listed below refers to your mains-operated (corded) appliance or battery-operated (cordless) appliance.

- Do not charge the appliance outdoors.
- Do not allow appliances to be used as a toy. Paying close attention is necessary when used by or near children.
- Use only as described in this manual. Use only manufacturer’s recommended attachments.
- Do not handle the battery or the appliance with wet hands.
- Do not put any object into openings. Do not use with any opening blocked; keep free of dust, lint, hair, and anything that may reduce air flow.
- Keep hair, loose clothing, fingers and all body parts away from openings and moving parts.
- Use extra care when cleaning on stairs.
- Do not operate the appliance in an explosive atmosphere, such as in the presence of flammable liquids, gases, or dust. Appliances create sparks that may ignite the dust or fumes.
- Store indoors. Do not expose to rain or water. Avoid direct sunshine.
- Never allow children to operate the appliance. Adults should not operate the appliance without proper instruction.
- Wear heavy long pants, boots, and gloves. Avoid loose garments or jewelry that could get caught in moving parts of the machine or its motor.
- Do not force appliance. Use the correct appliance for your application. The correct appliance will do the job better and safer at the rate for which it is designed.
- Keep firm footing and balance. Do not overreach. Overreaching can result in loss of balance.
- Any appliance that cannot be controlled with the switch is dangerous, and must be repaired.
- Do not operate this appliance when you are tired, ill, or under the influence of alcohol, drugs, or medication.
- Do not operate in poor lighting. Do not use to pick up flammable or combustible liquids, such as gasoline, or use in areas where they may be present.
- Do not pick up anything that is burning or smoking, such as cigarettes, matches, or hot ashes.
- Do not use without collection bin, filter or tube in place (if applicable).
- Do not use with damaged cord or plug. If appliance is not working as it should, has been dropped, damaged, left outdoors, or dropped into water, return it to a service center.
- Do not pull or carry by cord, use cord as a handle, close a door on cord, or pull cord around sharp edges or corners. Do not run appliance over cord. Keep cord away from heated surfaces.
- Turn off all controls before removing the battery pack.
- Do not use without proper filter in place.
- Always turn off this appliance before connecting or disconnecting either accessories.
- To reduce the risk of fire or electric shock, use appliance only with Greenworks identical parts and supply cords. If

- Do not use the appliance outdoors or on wet surfaces.

cord is damaged or lost, replace with identical replacement part.

- Follow all charging instructions and do not charge the battery pack or appliance outside of the temperature range specific in the instructions. Charging improperly or at temperatures outside of the specific range may damage the battery and increase the risk of fire.
- Do not modify or attempt to repair the appliance or the battery pack (as applicable) except as indicated in the instructions for use and care.
- Have your appliance serviced by a qualified repair person using only identical replacement parts. This will ensure that the safety of the power tool is maintained.
- Prevent unintentional starting. Ensure the switch is in the off-position before connecting to battery pack, picking up or carrying the appliance. Carry the appliance with your finger on the switch or energize appliance that have the switch on invites accidents.
- The machine is not intended for use by persons (including children) with reduced physical, sensory or mental capabilities, or lack of experience and knowledge, unless they have been given supervision or instruction concerning use of the machine by a person responsible for their safety. Children should be supervised to ensure that they do not play with the machine.

2.2 BATTERY-OPERATED APPLIANCES

- Do not use battery-operated appliance in rain.
- Recharge only with the charger specified by the manufacturer. A charger that is suitable for one type of battery pack may create a risk of fire when used with another battery pack.
- Use only the charger supplied by the manufacturer to recharge.
- Use appliances only with specifically designated battery packs. Use of any other battery packs may create a risk of injury and fire.
- Disconnect the battery pack from the appliance before making any adjustments, changing accessories, or storing the appliance. Such preventive safety measures reduce the risk of starting the appliance accidentally.
- When battery pack is not in use, keep it away from other metal objects like paper clips, coins, keys, nails, screws or other small metal objects that can make a connection from one terminal to another. Shorting the battery terminals together may cause burns or a fire.
- Under abusive conditions, liquid may be ejected from the battery; avoid contact. If contact accidentally occurs, flush with water. If liquid contacts eyes, immediately seek medical attention. Liquid ejected from the battery may cause irritation or burns.
- Do not incinerate the appliance even if it is severely damaged. The batteries can explode in a fire.
- Do not use a battery pack or appliance that is damaged or modified. Damaged or modified batteries may exhibit

unpredictable behavior resulting in fire, explosion or risk of injury.

- Do not expose a battery pack or appliance to fire or excessive temperature. Exposure to fire or temperature above 265°F (130°C) may cause an explosion.
- Unit should only be serviced by a qualified repair technician using only Greenworks replacement parts. This will prolong the life of the unit and maintain product safety.
- Don't modify or attempt to repair the appliance or the battery pack (as applicable) except as indicated in the instructions for use and care.
- Follow all charging instructions and do not charge the battery pack or appliance outside of the temperature range specified in the instructions. Charging improperly or at temperatures outside of the specified range may damage the battery and increase the risk of fire.



3 CHILD SAFETY





Tragic accidents can occur if the operator is not aware of the presence of children.

- Keep children out of the working area and under the watchful care of a responsible adult.
- Do not allow children under the age of 14 to operate this machine. Children who are 14 years of age and older must read and understand the operating instructions and safety rules in this manual and must be trained and supervised by a parent.
- Stay alert, and turn the machine off if a child or any other person enters the working area.
- Use extreme care when approaching blind corners, doorways, shrubs, trees, or other objects that may obscure your view of a child who may run into the path of the machine.

4 SYMBOLS ON THE PRODUCT



Some of the following symbols may be used on this product. Please study them and learn their meaning. Proper interpretation of these symbols will allow you to operate the product better and safer.

Symbol	Explanation
V	Voltage
A	Current
Hz	Frequency (cycles per second)
W	Power
min	Time
	Type or a characteristic of current
	Precautions that involve your safety.

Symbol	Explanation
	Read and understand all instructions before operating the product, and follow all warnings and safety instructions.
	Wear eye and ear protection.
	Thrown objects can ricochet and result in personal injury or property damage. Wear protective clothing and boots.
	Keep all bystanders at least 15m away.

5 RISK LEVELS

The following signal words and meanings are intended to explain the levels of risk associated with this product.

SYMBOL	SIGNAL	MEANING
	DANGER	Indicates an imminently hazardous situation, which, if not avoided, will result in death or serious injury.
	WARNING	Indicates a potentially hazardous situation, which, if not avoided, could result in death or serious injury.
	CAUTION	Indicates a potentially hazardous situation, which, if not avoided, may result in minor or moderate injury.
	CAUTION	(Without Safety Alert Symbol) Indicates a situation that may result in property damage.

6 ENVIRONMENTALLY SAFE BATTERY DISPOSAL



The toxic and corrosive materials below are in the batteries used in this machine: **Lithium-Ion, a toxic material.**

▲ WARNING

Discard all toxic materials in a specified manner to prevent contamination of the environment. Before discarding damaged or worn out Li-ion battery, contact your local waste disposal agency, or the local Environmental Protection Agency for information and specific instructions. Take the batteries to a local recycling and/or disposal center, certified for lithium-ion disposal.

▲ WARNING

If the battery pack cracks or breaks, with or without leaks, do not recharge it and do not use. Discard it and replace with a new battery pack. **DO NOT TRY TO REPAIR IT!** To prevent injury and risk of fire, explosion, or electric shock, and to avoid damage to the environment:

- Cover the terminals of the battery with heavy-duty adhesive tape.
- **DO NOT** try to remove or destroy any of the battery pack components.
- **DO NOT** try to open the battery pack.
- If a leak develops, the released electrolytes are corrosive and toxic. **DO NOT** get the solution in the eyes or on skin, and do not swallow it.
- **DO NOT** put these batteries in your regular household trash.
- **DO NOT** incinerate.
- **DO NOT** put them where they will become part of any waste landfill or municipal solid waste stream.
- Take them to a certified recycling or disposal center.

7 SAVE THESE INSTRUCTIONS

8 INSTALLATION

- Replace the battery pack or the charger immediately if the battery pack or charger cord is damaged.
- Exam that the machine is in the OFF status before you install or remove the battery pack.

8.1 UNPACK THE MACHINE

▲ WARNING

Make sure that you correctly assemble the machine before use.

▲ WARNING

- If parts of the machine are damaged, do not use the machine.
- If you do not have all the parts, do not operate the machine.
- If parts are damaged or missing, contact the service center.

1. Open the package.
2. Read the documentation provided in the box.
3. Remove all the unassembled parts from the box.
4. Remove the machine from the box.
5. Discard the box and packing material in compliance with local regulations.

8.2 INSTALL THE FILTER

▲ WARNING

To prevent accidental starting that could cause serious personal injury, always remove the battery pack from the tool when assembling parts.

1. Lift the latch (7) on both sides of the top cover assembly.

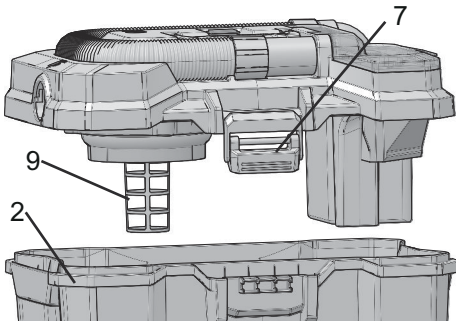

2. Align the filter (3) with the filter cage (9).

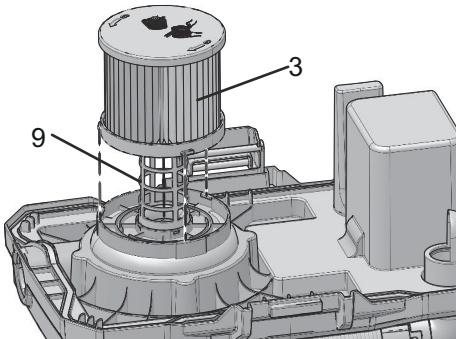

3. Slide the filter (3) on the filter cage (9).

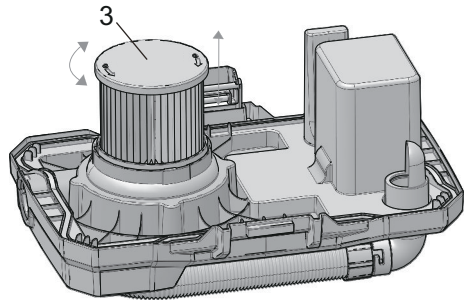

4. Rotate and twist the filter (3) into place.

8.3 REMOVE THE FILTER

1. Lift the latch (7) on both sides of the top cover assembly.
2. Remove the collection tank (2).
3. Turn the filter (3) counterclockwise.
4. Slide the filter off.

8.4 INSERT THE HOSE

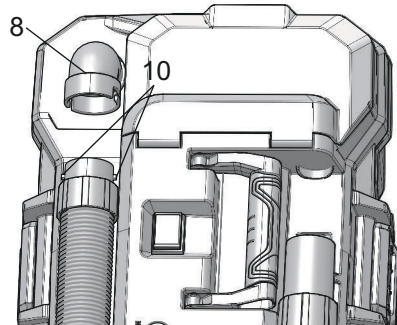

1. Align either of the grooves (10) in the tube with the tabs on the hose.
2. Insert the locking end of the hose into the vacuum port (8) and turn clockwise to lock into place.

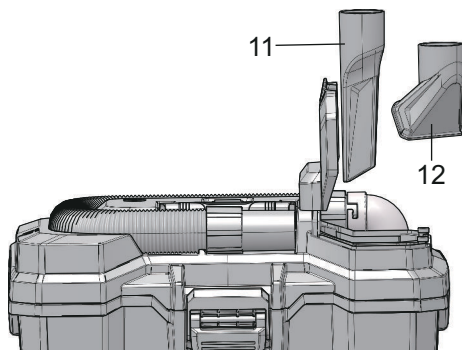

3. Insert your desired accessory (11/12) onto the end of the hose securely.

i NOTE

To remove the hose, turn the locking end of the hose counter-clockwise.

8.5 INSTALL THE BATTERY PACK

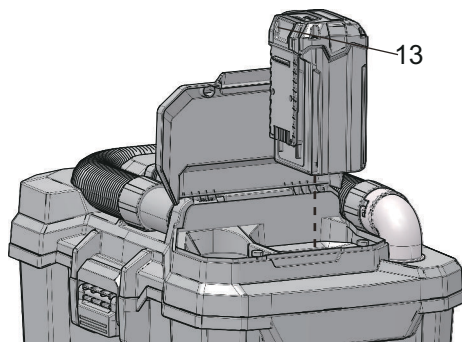

▲ WARNING

- If the battery pack or charger is damaged, replace the battery pack or the charger.
- Stop the machine and wait until the engine stops before you install or remove the battery pack.
- Read, know, and do the instructions in the battery and charger manual.

1. Open the battery door.
2. Align the lift ribs on the battery pack with the grooves in the battery compartment.
3. Push the battery pack into the battery compartment until the battery pack locks into place.
4. When you hear a click, the battery pack is installed.
5. Close the battery door.

8.6 REMOVE THE BATTERY PACK

1. Open the battery door.
2. Push and hold the battery release button (13).
3. Remove the battery pack from the machine.

9 OPERATION

▲ WARNING

Do not handle battery pack, switch, or machine with wet hands. Do not expose to rain or allow liquid to enter the motor compartment.

9.1 START THE MACHINE

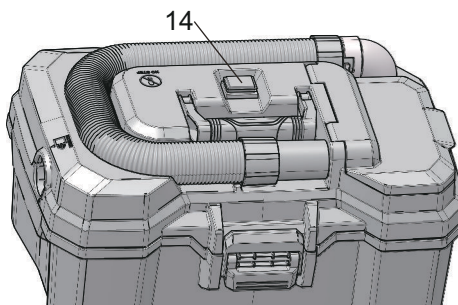

1. Push the on/off button (14) to turn the machine on.

▲ WARNING

Hold the machine with hands during operation.

i NOTE

If you want to start the machine again please wait until the machine completely stops.

9.2 STOP THE MACHINE

1. Set the ON / OFF switch to the off position.

9.3 BLOWING FEATURE

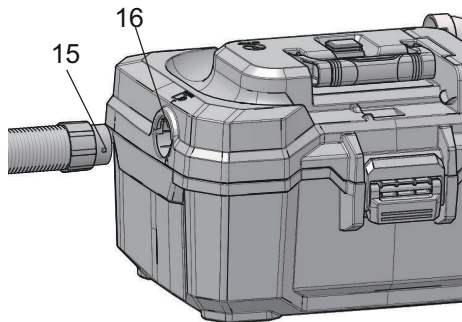

The wet/dry vac can blow sawdust and other debris. Complete the steps below to use your machine as a blower.

1. Align either of the grooves (16) in the tube with the tabs (15) on the hose.
2. Attach the desired accessory to the end of hose.
3. Start the machine.

9.4 OPERATION TIPS

- The filter must always be in correct position to avoid leaks and possible damage to the machine.
- When you use your machine, it will be necessary for you to empty the collection tank and clean the filter at more frequent intervals to maintain peak vac performance.
- When the liquid in the collection tank reaches a predetermined level, the float mechanism will rise automatically to cut off air-flow. This will cause the suction stop and the higher motor noise. When this happens:
 1. Turn off the machine.
 2. Remove the battery pack.
 3. Empty the collection tank.
- Dry the filter after you use the machine to avoid mildew and damage to the machine.

10 MAINTENANCE

▲ CAUTION

Do not let brake fluids, gasoline, petroleum-based materials touch the plastic parts. Chemicals can cause damage to the plastic, and make the plastic unserviceable.

▲ CAUTION

Do not use strong solvents or detergents on the plastic housing or components.

▲ WARNING

Remove the battery pack from the machine before maintenance.

10.1 CLEAN THE FILTER

i NOTE

Allow the filter to dry before storing the machine or picking up debris.

Clean the wet/dry vac filter frequently to maintain optimal performance.

Cleaning a dry filter:

- Cleaning should be done outdoors and not in the living quarters.
- You can use a small brush to clean the dust and debris.
- For thorough cleaning of dry filter with fine dust (no debris), run water through it as described under "Cleaning A Wet Filter"

Cleaning a wet filter:

1. Remove the filter from the machine.
2. Run water through the filter from a hose or spigot.

i NOTE

Check the cartridge filter for tears or small holes after cleaning. Do not use a cartridge filter with holes or tears in it. Even a small hole can allow dust to come out of your machine. Replace it immediately.

10.2 CLEAN THE MACHINE

To keep your machine looking its best, clean the outside with a cloth dampened with warm water and mild soap.

To clean the collection tank:

- Dump debris out.
- Wash collection tank with warm water and mild soap.
- You can use a small brush to clean the dust and debris.
- Wipe out with dry cloth.

To disinfect the collection tank:

1. Pour 1 gallon of water and 1 teaspoon chlorine bleach into the collection tank.
2. Let solution stand for 20 minutes, carefully swishing every few minutes, making sure to wet all inside surfaces of the collection tank.
3. Empty collection tank after 20 minutes. Rinse with water until bleach smell is gone. Allow collection tank to dry completely before sealing the motor on the collection tank.

i NOTE

Disinfect the collection tank before storage or as needed.

11 STORE THE MACHINE

i NOTE

Clean the machine before storage.

1. Remove the battery pack.
2. Let the motor cool.
3. Check that there are no loose or damaged components. If it is necessary, replace the damaged components, tighten screws and bolts, or speak to a person of an approved service center.
4. Store the machine in a cool and dry location.

12 TROUBLESHOOTING

Problem	Possible cause	Solution
The machine doesn't work.	The switch or motor is defective.	Speak to service center.
Dust discharges from exhaust.	The filter has damage.	Replace the filter.
	The filter isn't installed.	Properly reinstall the filter.
	The filter is not functional.	Clean or replace the filter.
	The filter clogs.	Clean or replace the filter.
Loss of suction	The hose connection loose.	Tighten the hose connection.
	The filter clogs.	Clean or replace the filter.
	The collection tank is full.	Empty the collection tank.
	The hose has damage.	Replace the hose.
Static shock	The environment is dry.	Add moisture to air (if practical, use a humidifier).

13 TECHNICAL DATA

Voltage	24 V
Tanksize	3 gallons
Air Volume	65 CFM
Max suction	12 kPa
Weight (without battery pack)	11.46 lbs. (5.2 kg)
Hose	7-ft extenable hose
Accessory	Crevice and utility tool

Battery model	BAG708 and other BAG series
Charge model	CAG801 and other CAG series

The recommended ambient temperature range:

Item	Temperature
Vacuum storage temperature range	32°F (0°C) - 113°F (45°C)
Vacuum operation temperature range	32°F (0°C) - 113°F (45°C)
Battery charging temperature range	39°F (4°C) - 104°F (40°C)
Charger operation temperature range	39°F (4°C) - 104°F (40°C)
Battery storage temperature range	32°F (0°C) - 113°F (45°C)
Battery discharging temperature range	32°F (0°C) - 113°F (45°C)

14 LIMITED WARRANTY



Greenworks hereby warranties this product, to the original purchaser with proof of purchase, for a period of three (3) years against defects in materials, parts or workmanship. Greenworks, at its own discretion, will repair or replace any and all parts found to be defective, through normal use, free of charge to the customer. This warranty is valid only for units which have been used for personal use that have not been purchased or rented for industrial/commercial use, and that have been maintained in accordance with the instructions in the owners' manual supplied with the product when new.

ITEMS NOT COVERED BY WARRANTY:

1. Any part that has become inoperative due to misuse, commercial use, abuse, neglect, accident, improper maintenance, or alteration; or
2. The unit, if it has not been operated and/or maintained in accordance with the owner's manual; or
3. Normal wear;
4. Routine maintenance items such as lubricants, blade sharpening;
5. Normal deterioration of the exterior finish due to use or exposure.

HELPLINE:

Warranty service is available by calling our toll-free helpline at 1-888-909-6757.

TRANSPORTATION CHARGES:

Transportation charges for the movement of any power equipment unit or attachment are the responsibility of the purchaser. It is the purchaser's responsibility to pay transportation charges for any part submitted for replacement under this warranty unless such return is requested in writing by Greenworks.

USA address:

Greenworks Tools

P.O. Box 1238

Mooresville, NC 28115

Canadian address:

Greenworks Tools Canada, Inc.

P.O. Box 93095, Newmarket,
Ontario

L3Y 8K3

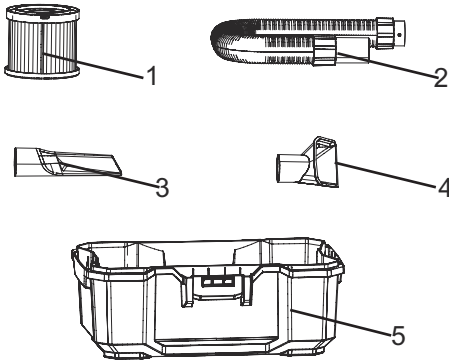
15 EXPLODED VIEW

No.	Part No.	Description	Qty
1	R0400214-00	Filter	1
2	R0400215-00	Hose	1
3	R0400216-00	Crevice Tool	1
4	R0400217-00	Utility Nozzle	1
5	R0202464-00	Collection tank	1